

PCM DRIVER™ CD-250

THE SURFACE DRIVE SOLUTION FOR YOUR
PCP OPERATIONS

keep it moving 

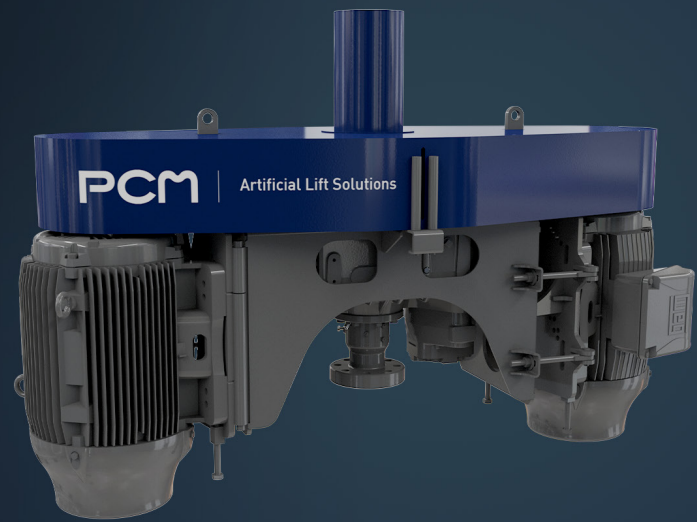

CD-250

Designed with the latest technology to ensure full compliance with Oil and Gas standards, PCM Driver™ driveheads are safe and reliable surface drive solutions specifically engineered for long life in all your PCP operations.

The design and the qualification of the PCM Driver™ driveheads comply with ISO 15136-2-Surface Drive System requirements.

The **PCM Driver™ CD-250** is a cost-effective full life cycle solution to perform with all your power requirements up to **250 HP**.

» BENEFITS

- Fully internal brake system
- Patented environmental **PCM EcoSeal Stuffing Box**
- Rotating parts fully covered
- Low maintenance requirements
- Associated service and technical support

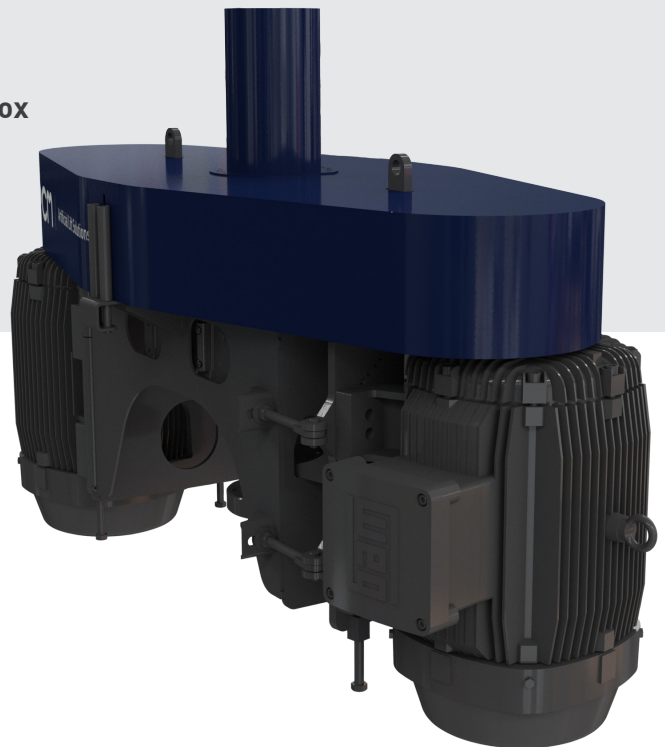

PCM

Artificial Lift Solutions

SAFETY

Belt guard:

- compact and durable, all rotating parts fully protected

Fully internal brake system:

- Efficient backspin control
- Adjustable brake sensitivity

Anti-ejection system available for polished rod clamp.

ATEX certification is available.

LOW MAINTENANCE REQUIREMENT

Only maintenance required is regular visual inspection, seal greasing, and oil changes.

PCM EcoSeal Stuffing Box – Patented environmental integral rotating sealing system

- Redundant seals
- No seepage
- Long life

FIRST CLASS SERVICE

- PCM Service team available worldwide to support customer
- Dedicated PCP team will support customer regarding any queries or issues faced with our PCM Driver™.

SPECIFICATIONS

Drive mode	Belt and pulleys driven; two electric motors
Max driven sheave	31.5" (800 mm)
Ambient conditions	-40°F to 105°F (-40°C to +40°C)
Braking system	Internal gear pump with adjustable control valve
Max speed	500 RPM
Max Torque	3 500 ft. lb. (or 4 750 N.m)
Sealing system	PCM EcoSeal Stuffing Box
Max Temperature	390°F (200°C)
Max Pressure	Dynamic: 1 000 PSI (70 Bar) Static: 1 000 PSI (70 Bar)
Shaft type	Hollow shaft
PR diameter	1"1/4 (31.75 mm) or 1"1/2 (38.10 mm)
API Wellhead	Flanged 3" 1/8 3M R31 or 4" 1/16 3M R37 or 5" 1/8 3M R41
Bearing dynamic axial load rating (Ca, ISO 281)	380 500 lb (1 470 kN)
Bearing dynamic axial load rating (Ca90)	85 700 lb (381 kN)
Bearing load for L10 life of 25 000 hours at 500 RPM	20.6 T
Prime mover	Dual electric motors NEMA or IEC
Max. Motor HP	2 x 125 HP (2 x 93 kW) 250 HP (186 kW) total
Max. noise level	< 70 dB
Total Weight	2 100 lb (952 kg)
Dimensions	79" x 36.7" x 44.5" (2.01 x 0.93 x 1.13 m)

For further information, please contact your PCM local representative:

www.pcmals.com